



PROVINCIA DI TORINO
www.provincia.torino.gov.it



FPMCI
Fondo Provinciale Milanese per
la Cooperazione Internazionale
www.cooperazionemilanese.org



PDA
Planning and Local Development Agency
Municipalities Union of Hermel - Lebanon
www.hermeldevelopment.org



PROJECT FUNDED BY EUROPEAN UNION
Partnership for urban renewal project towards regional
economic development - P.P.R.U.
ENPI-2009/203-617



**DEVELOPMENT PROGRAM FOR THE ORGANISATION
OF THE INDUSTRIAL AND HANDICRAFT SECTOR IN HERMEL**

Object
**HANDCRAFT AREA
AND LOCAL MARKET**
DRAFT PROJECT

december 2013

Architectural Design
ARCò - Architettura e Cooperazione
Società Cooperativa
Via Friuli, 26/A
20135 - Milano, Italy



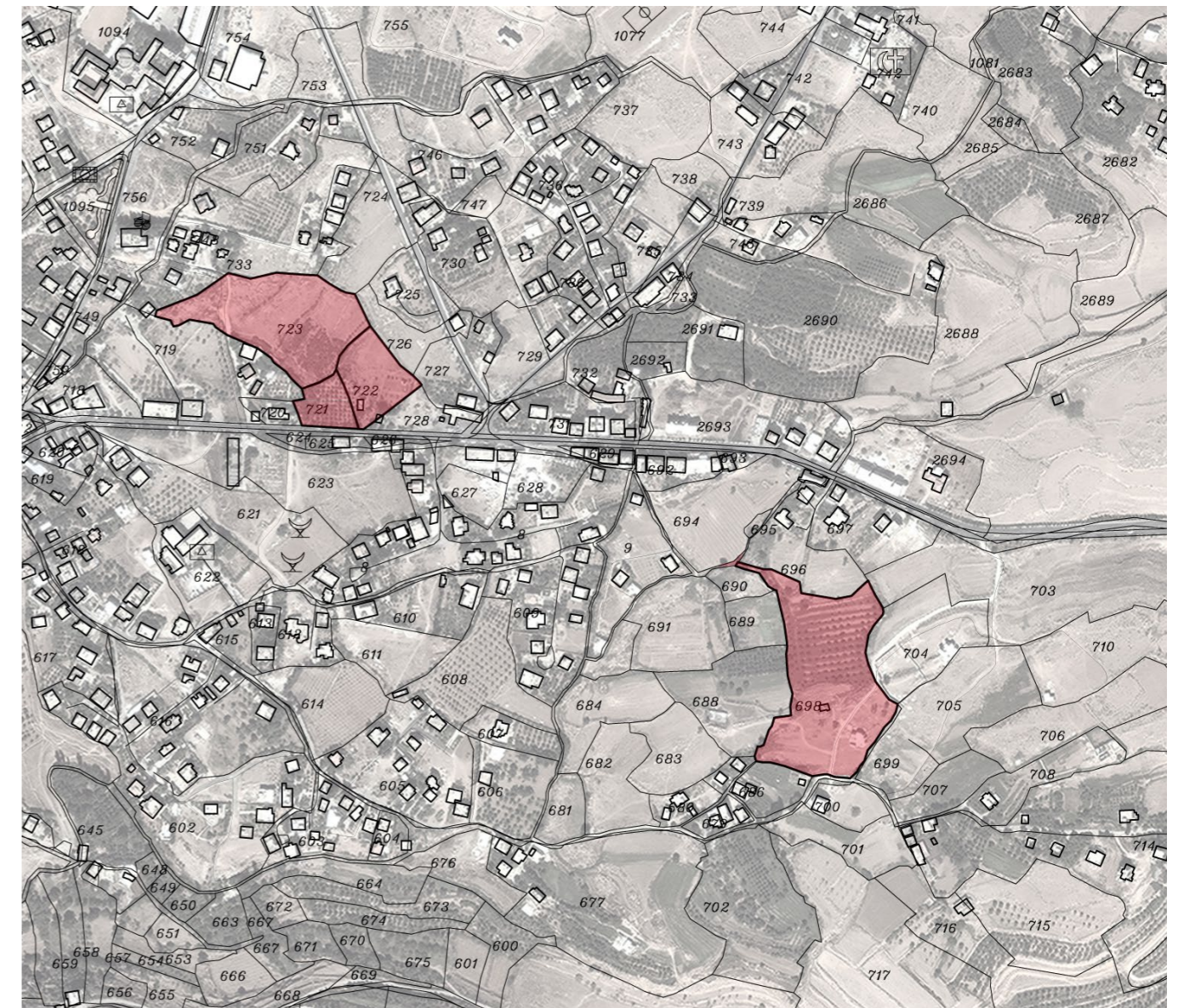

The city of Hermel is the capital of the Hermel region, and lies in the north of Lebanon. The region is mostly mountainous, the city has a population of 80,000 people and has an immigration of 50%. The development plan has identified two main problems for Hermel: 1 there is no area for small industries and crafts; 2 there is no market or a close wholesale center.

The purchase of fruits and vegetables are from several sources, but the closest to the region is about one hour and a half. There are several industries and crafts in the area but a field survey shows that the total shops rented by the industrialists of 150 out of 200 shops rent ranges between \$ 100 and \$ 300 at an average \$ 200 a month, "while the number of shops owned by industrialists reach only 50 shops.

LOCAL MARKET

The project starts from the memory of a caravanserai, main historical reference for arabic markets. It interprets the reference in a contemporary way, considering the particular needs of Hermel. The result is an open air public space, shadowed and organized to host the wholesale activity. The main principles are:

- functionality, flexibility and modularity
- water collection, energy self sufficiency
- self construction

All the sales areas are divided by cabinets, that contain the materials for the counters. So the seller can reach the place with a truck, can leave the product in frigo cells, and build quickly his own counter, that can disassemble at the end of the day preserving and protecting his own material.

LOCAL MARKET

MAIN POINTS

- local position near Hermel
- flexibility, adaptable to different products
- modular approach and possible extension
- public spaces for workers
- water collection
- self construction

PROGRAM

- sales areas
- wholesale distribution
- refrigeration section
- parking for trucks
- space for offices
- small dining area
- garbage collection points
- parking area for customers
- common services

SELLER TYPOLOGY

- vegetables
- fruits
- meat

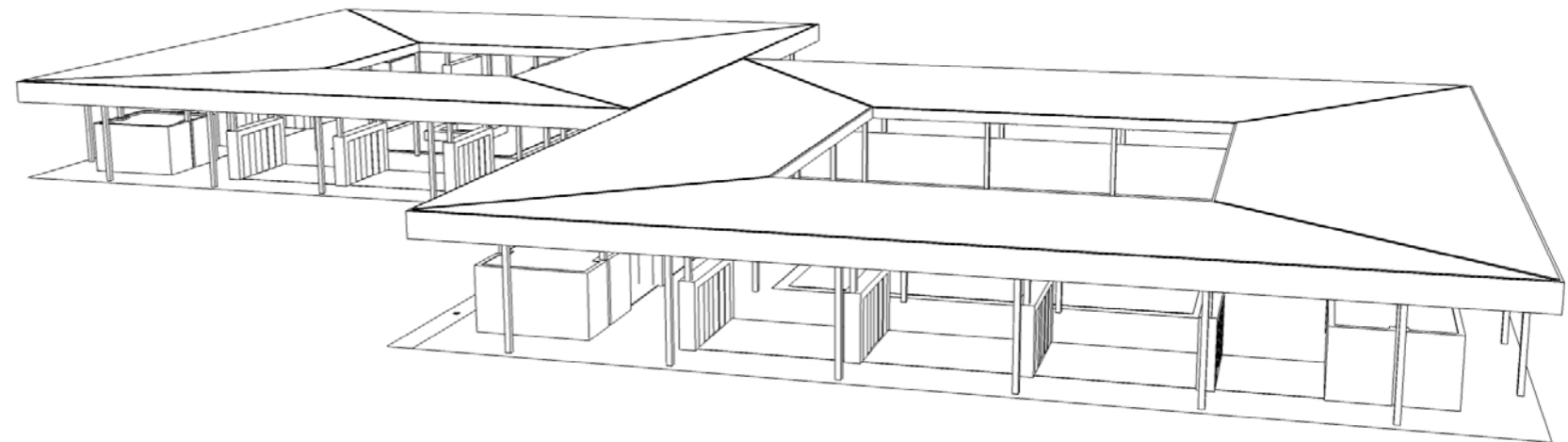

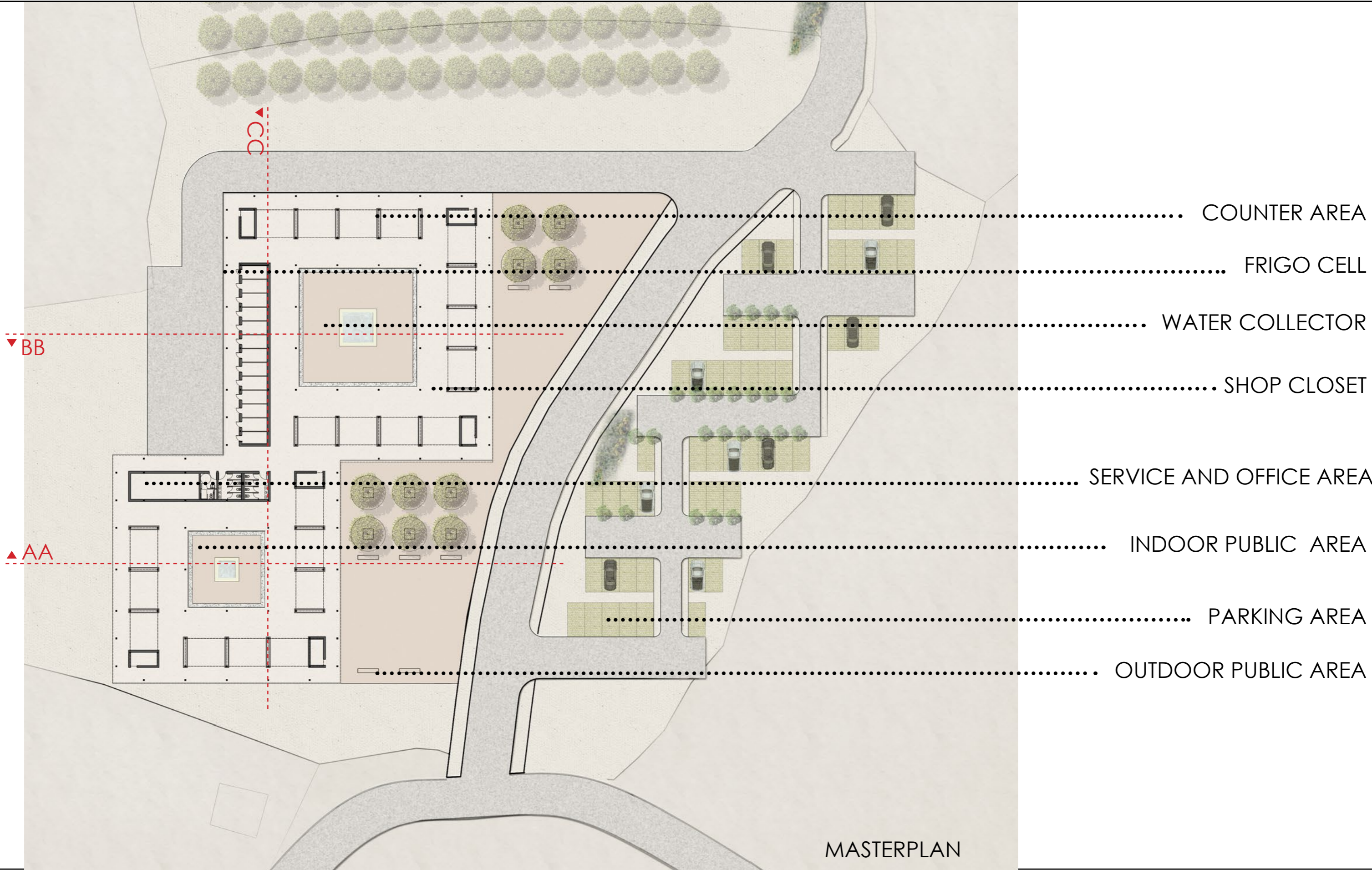

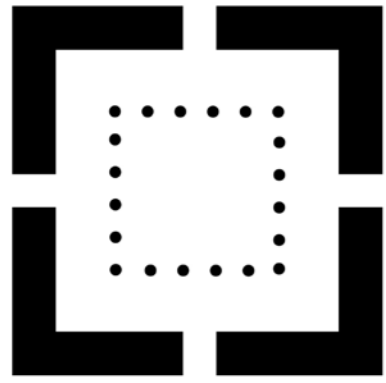

REFERENCE PLAN:
CARAVANSERAI

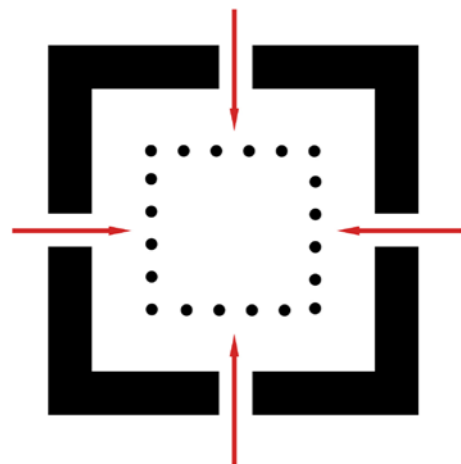

CARAVANSERAI
ACCESS

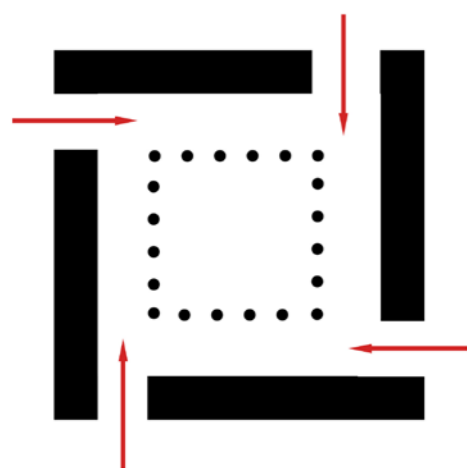

SCHEME OF PROJECT
PLAN AND ACCESS

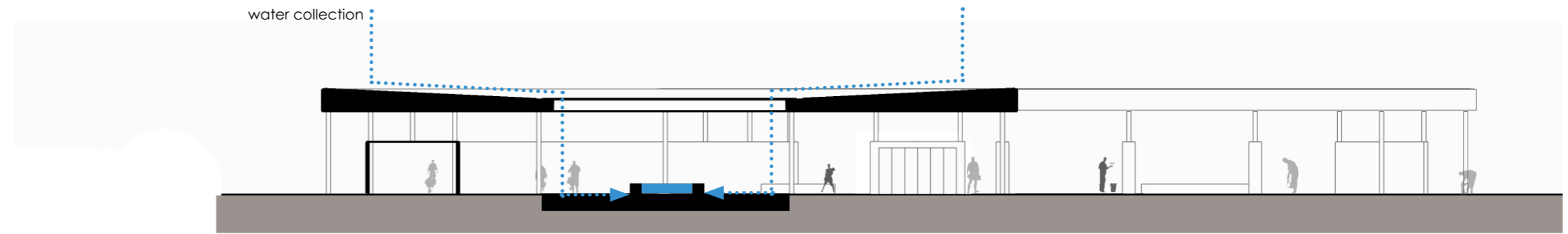

SECTION AA

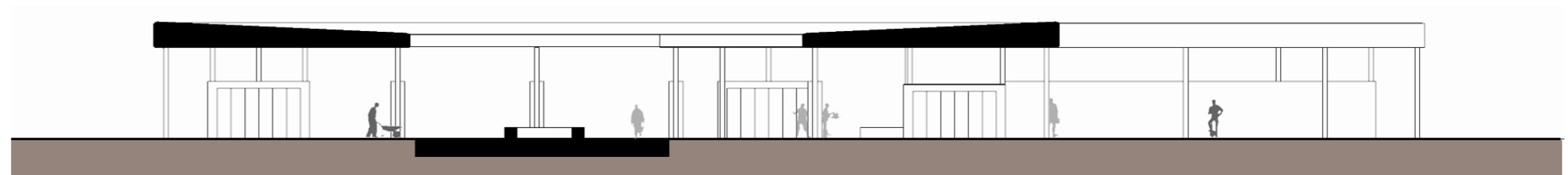

SECTION BB

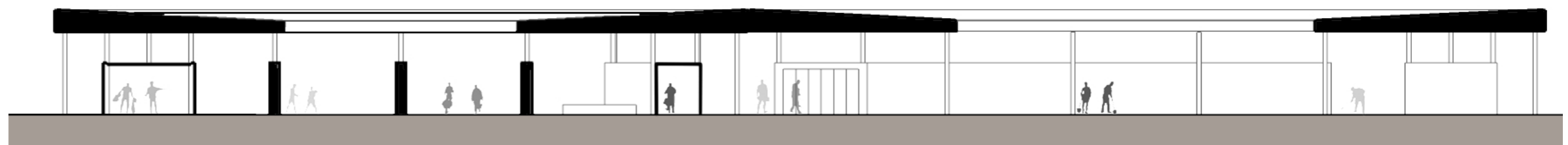

SECTION CC

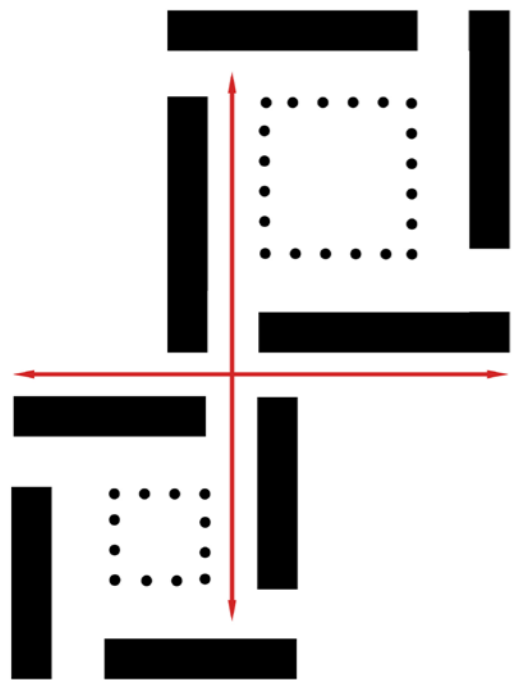

MAIN AXES

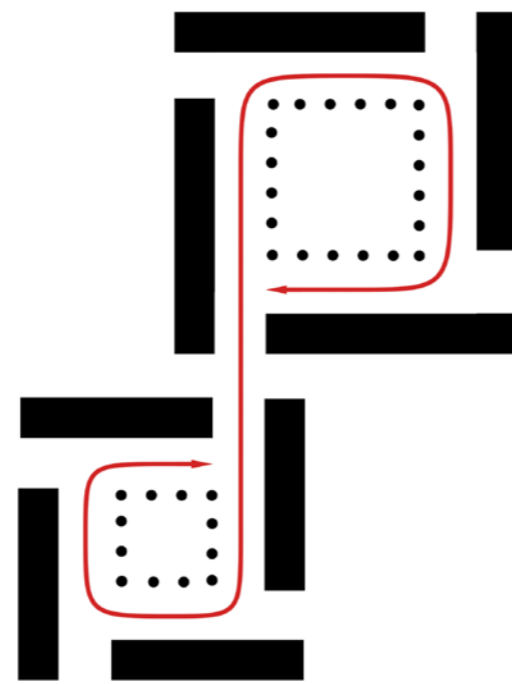

CIRCULATION

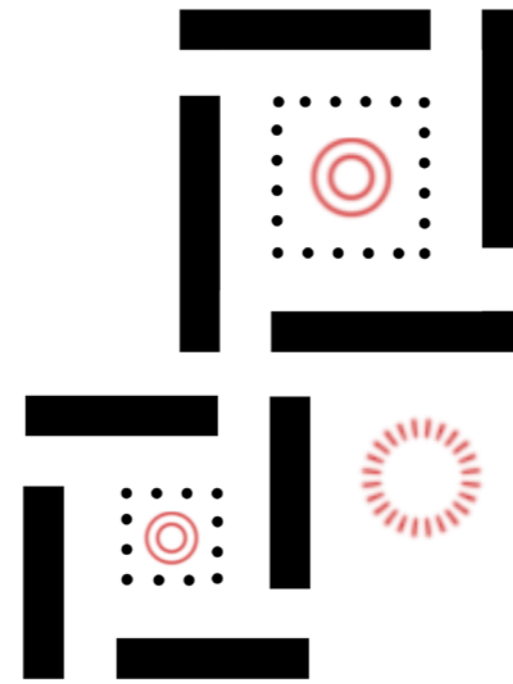

PUBLIC SPACES

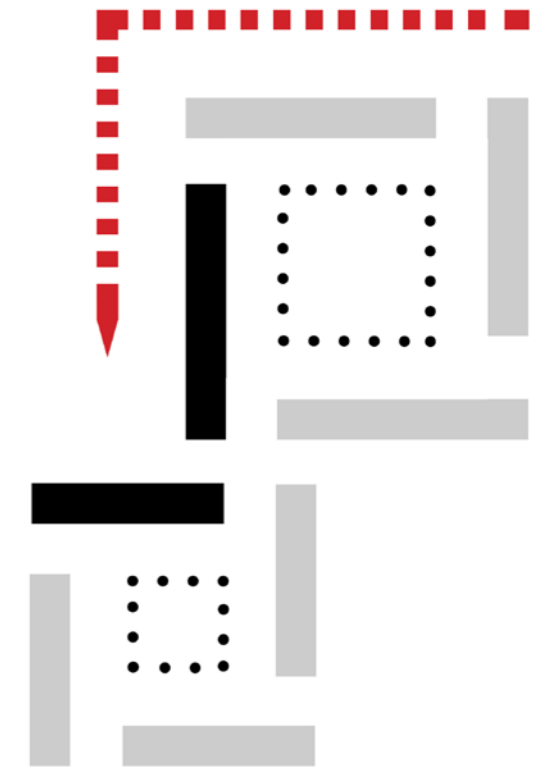

ACCESS FOR GOODS UNLOADING



CONSTRUCTED SPACES

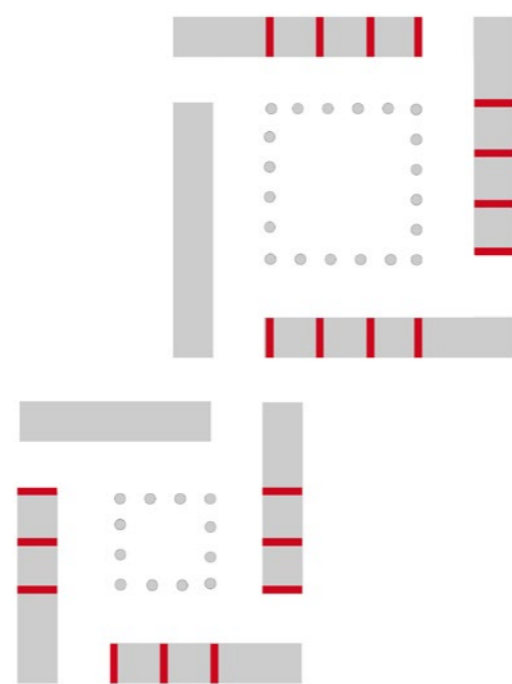

MARKET BOXES SYSTEM
CLOSED BOXES

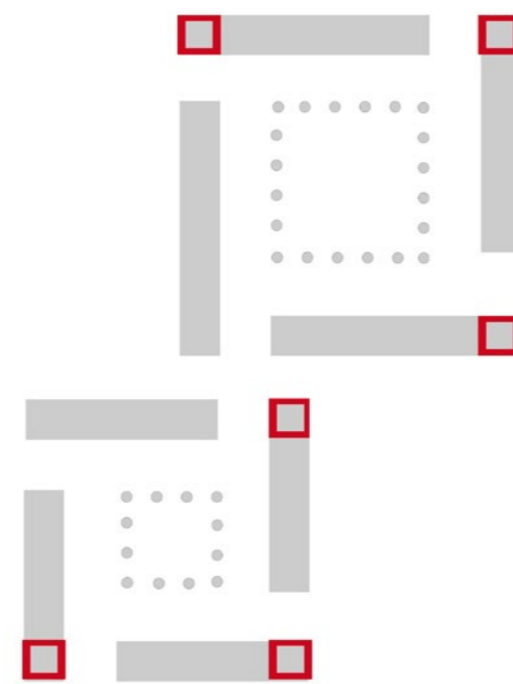

GARBAGE SPACES

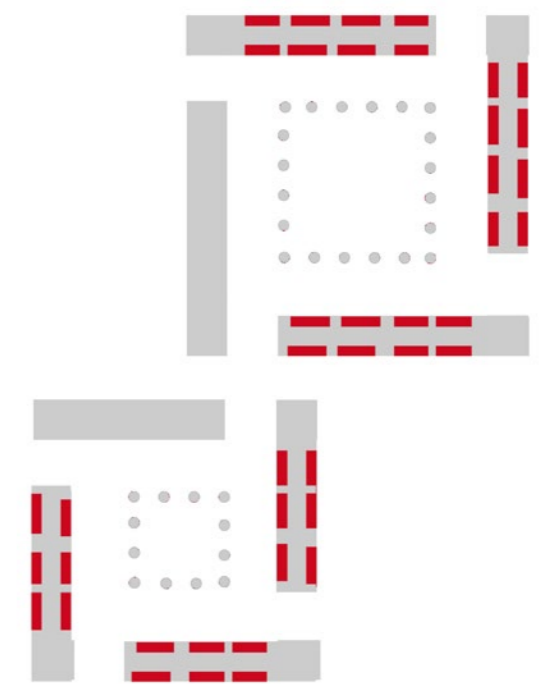

MARKET OPEN

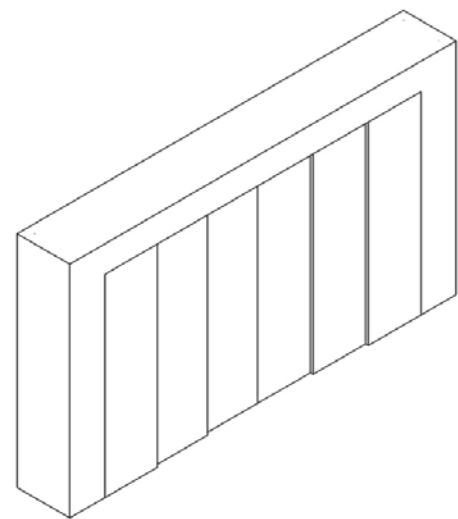

1.

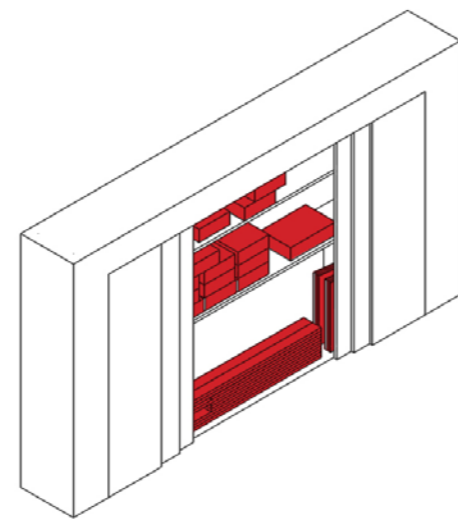

2.

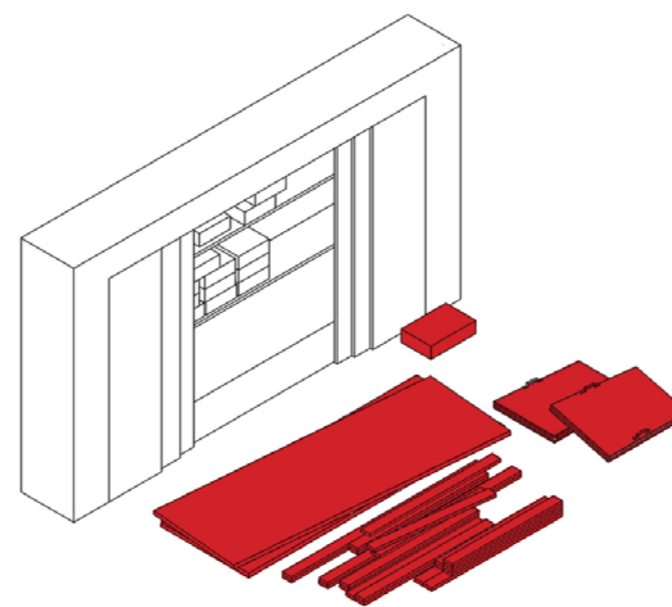

3.

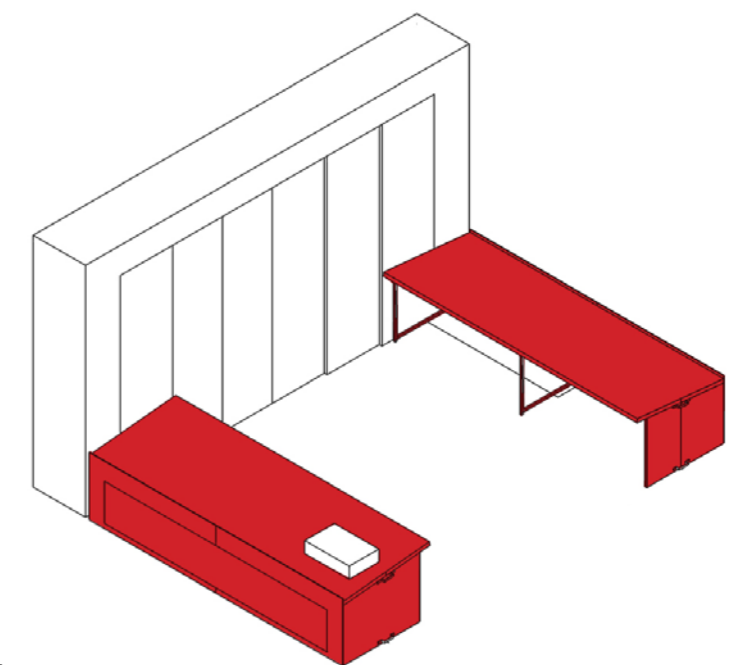

4.

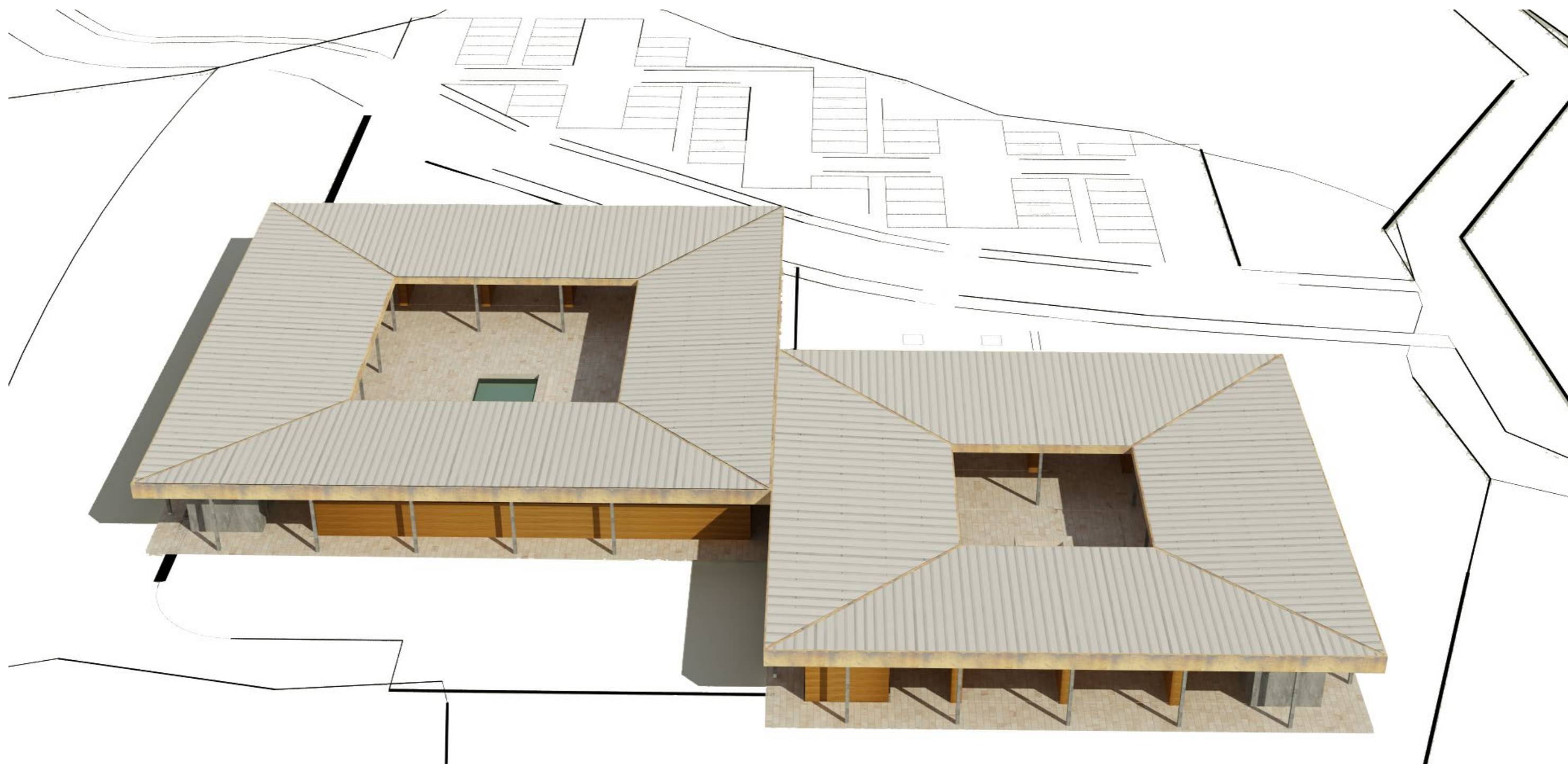

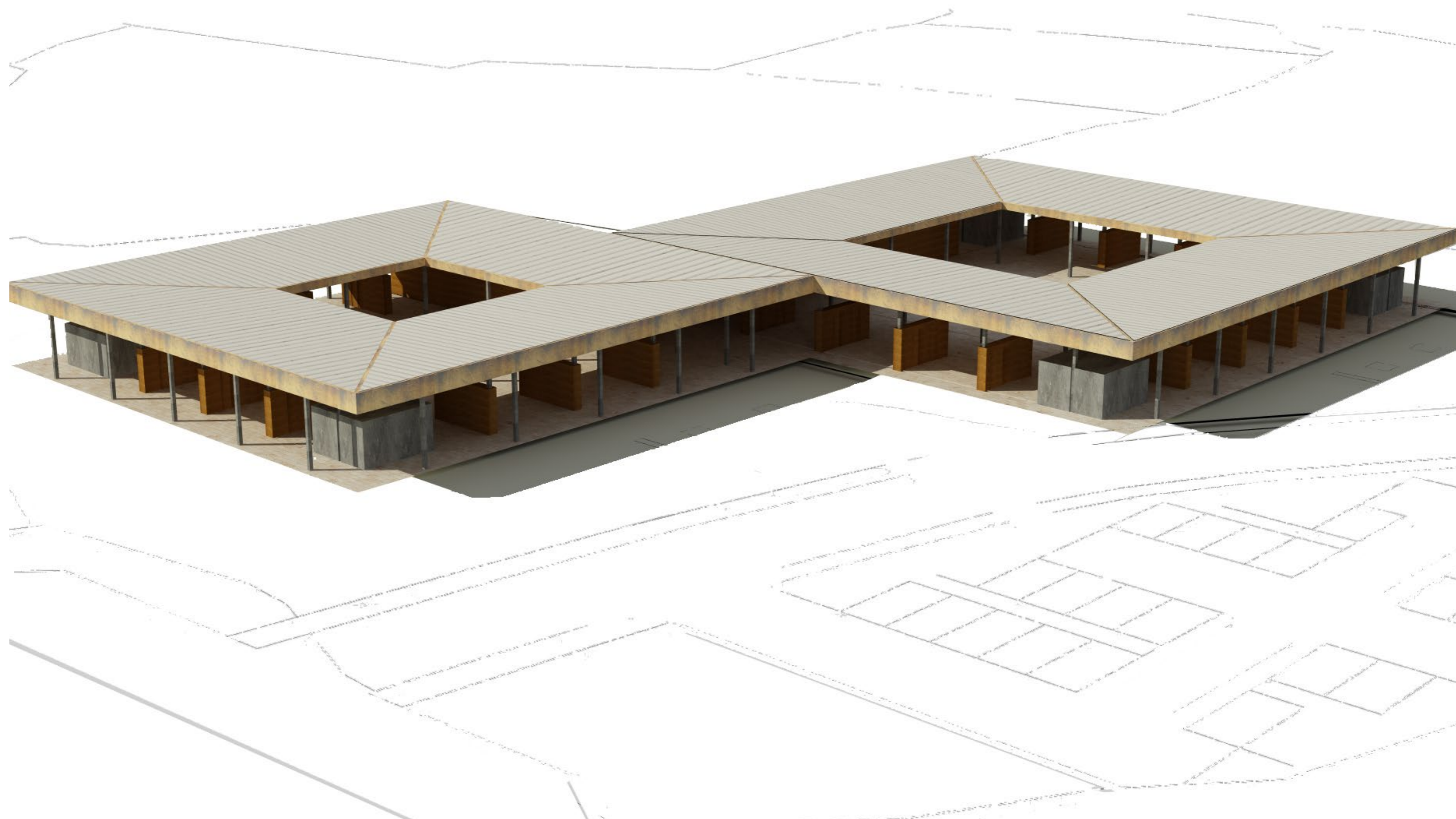



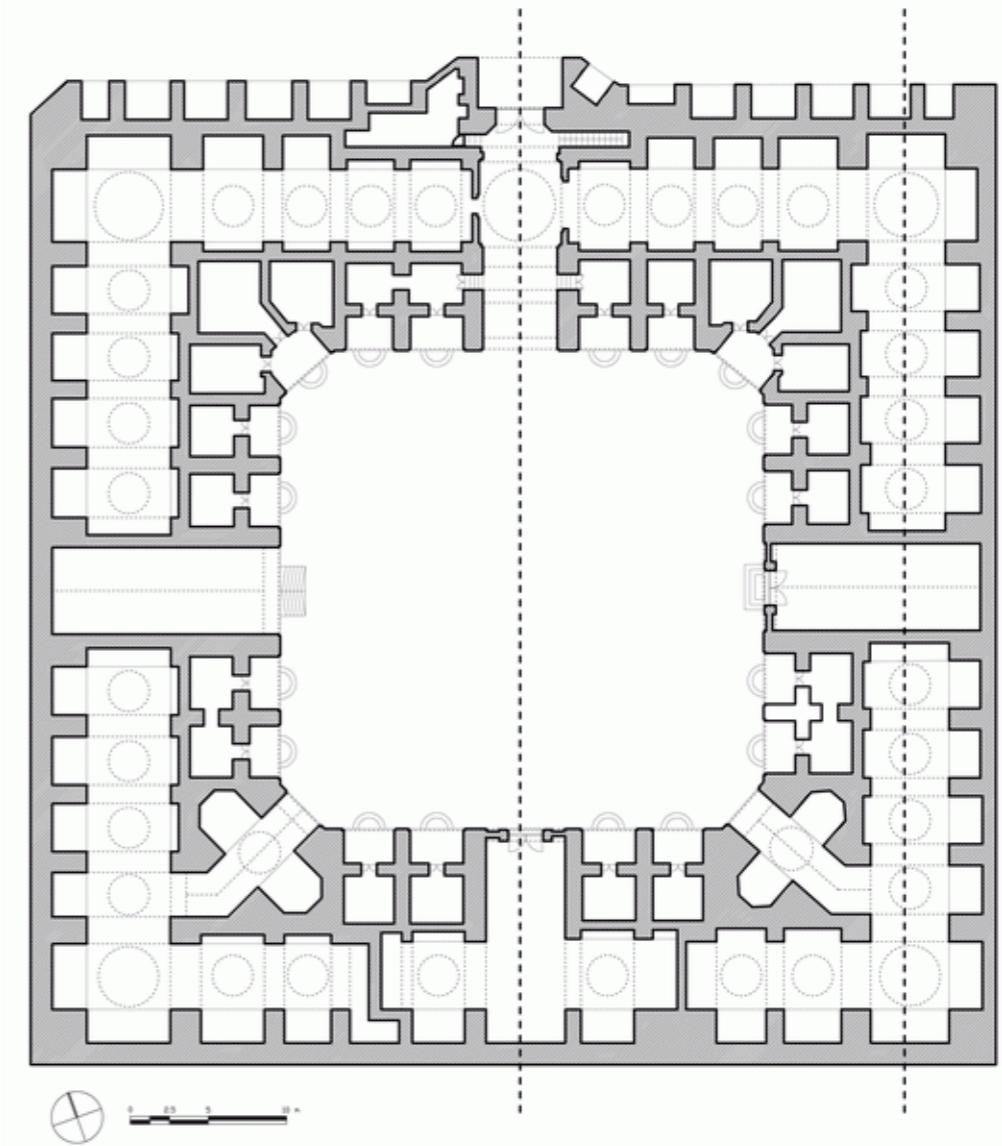

'600 CARAVANSERAI RESTAURATION, KHAN AL-WAKALA
Laboratorio Marco Bacci
2012 - Nablus, Palestine



BOUQUINISTE DE PARIS
'70, Paris



NO-MADE CASE

Antonina Guggiardi

2011 - Milano, Cascina Cuccagna

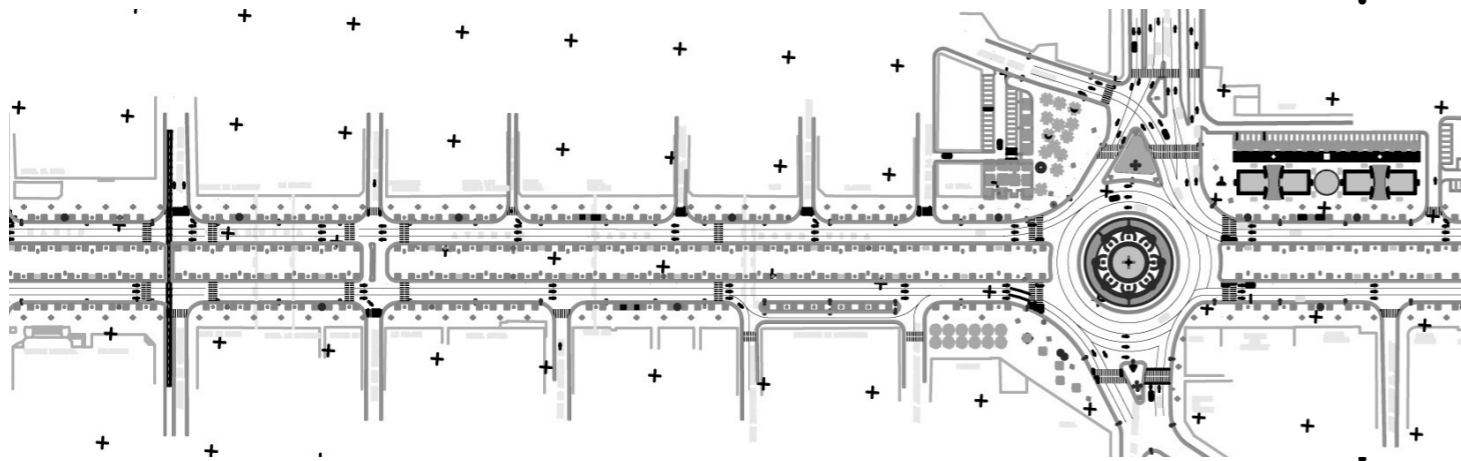

REVITALISATION OF RECENT HERITAGE

Association de Sauvegarde de la Médina de Tunis (ASM)
2007 - Tunis

Object

**HANDCRAFT AREA
AND LOCAL MARKET**
DRAFT PROJECT

december 2013

Architectural Design

ARCò - Architettura e Cooperazione

Società Cooperativa

Via Friuli, 26/A

20135 - Milano, Italy

info@ar-co.org

www.ar-co.org



Collaborators

Maura Carassai

Dounia Fert

Lucrezia Morandi

Lisa Sghirlanzoni